

CC Series

ASA Series 40/60lpm



General Data And Details

The oil / air coolers of our CC series are autonomous cooling systems with an integrated circulation pump. They work as a separate cooling unit or as a filter cooling unit with an adequate filter. The benefits of such circulation coolers are a constant cooling performance and a higher durability, because there are no pressure vibrations or peaks in the cooler unit.

Conditions of use:

Maximum oil temperature: 80°C, maximum air temperature: 50°C. Motors can be used up to an altitude of 1.500m. For other conditions of use please contact our engineers.

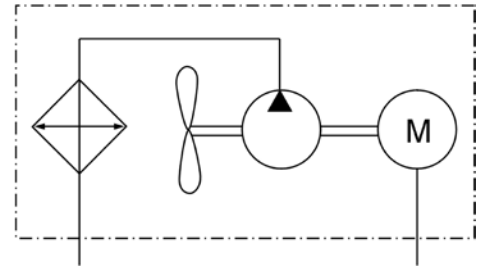

Connection asa uc

The **AUC (asa universal connector)** system was the first worldwide flexible connection system for air blast heat exchangers. It gives you the free choice of the connector direction through turnable ports in 3 directions. Also the dimension of the ports can be varied with optional types. Please contact us to discover the huge potential of this system for your application.

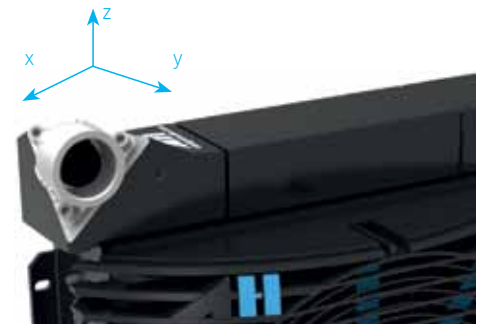

Scale Drawing

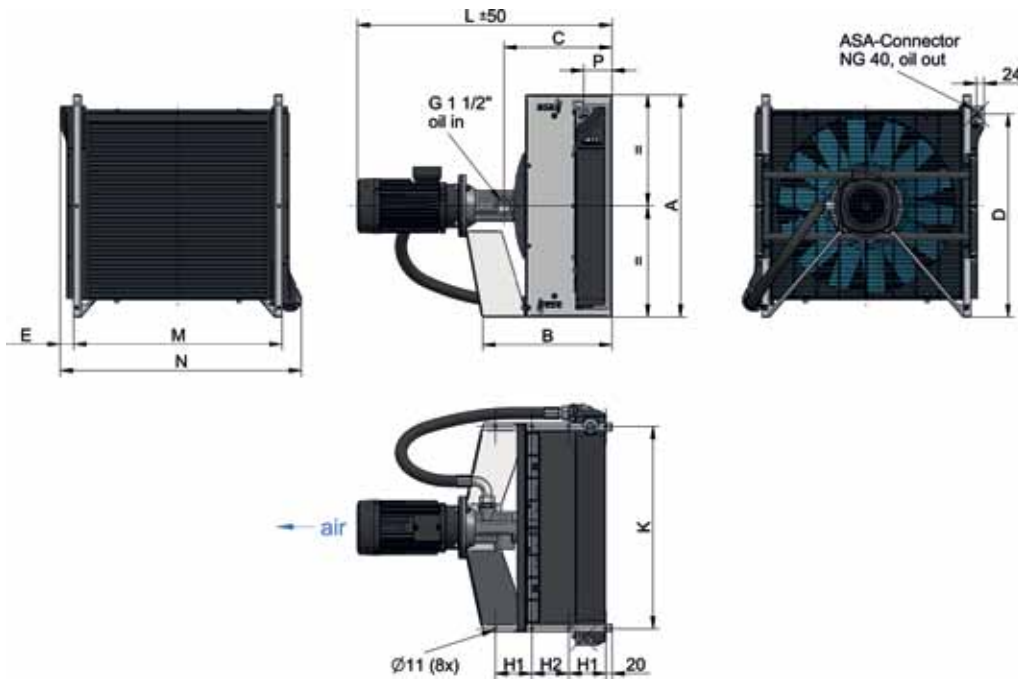

order number	description	A	B	C	D	E	H1	H2	K	L	M	N	P
		[mm]	[mm]	[mm]	[mm]	[mm]	[mm]	[mm]	[mm]	[mm]	[mm]	[mm]	[mm]
ASA0177AA49CC	ASA 0177 CC 4-pol	530	400	331	471	60	120	90	442	807	462	601	89
ASA0257AA49CC	ASA 0257 CC 4-pol	635	410	341	568	60	110	110	542	817	562	701	93
ASA0367AA49CC	ASA 0367 CC 4-pol	720	420	351	658	46	120	120	656	827	676	781	92
ASA0467AA49CC	ASA 0467 CC 4-pol	785	426	367	727	40	125	125	738	843	758	856	94
ASA0567AA49CC	ASA 0567 CC 4-pol	860	416	361	802	43	125	125	806	837	826	931	94
ASA0177AA68CC	ASA 0177 CC 6-pol	530	400	331	471	60	120	90	442	807	462	601	89
ASA0257AA68CC	ASA 0257 CC 6-pol	635	410	341	568	60	110	110	542	817	562	701	93
ASA0367AA68CC	ASA 0367 CC 6-pol	720	420	351	658	46	120	120	656	827	676	781	93
ASA0467AA68CC	ASA 0467 CC 6-pol	785	426	367	727	40	125	125	738	843	758	856	92
ASA0567AA68CC	ASA 0567 CC 6-pol	860	416	361	802	43	125	125	806	837	826	931	94

This data sheet and the corresponding scale drawings are to be used as a general guideline and technical overview of our products. Please contact us if more exact information is needed. As we are constantly improving our products, their characteristics, dimensions and weights may also change, although we do our best to incorporate these changes continually. asa assumes no liability for any information therein, any errors, omissions, misprints, nor any direct or indirect damages, losses or costs resulting therefrom. Any cooling performances and general technical values indicated in this catalogue are measured at a test bench according to asa testing procedures or calculated, based on such tests. Due to different conditions in testing and application environments the performance may also vary by +/- 15%. Because there is no standardized testing procedure, tests used by other manufacturers could have different results. Therefore we recommend all products to be checked under the system operating conditions. This is also true for vibrations and mechanical stress as well as for pressure peaks and thermal stress and any other relevant factors. General tolerances according to DIN ISO 2768-v. General tolerances for casted parts according to EN ISO 8062-3 (DCTG 10). Tolerances for rubber parts are according to ISO 3302-1 (class M4-F+C). The tolerances of welding seams are defined by quality group D according to EN ISO 10042, if it is not specified on the actual scale drawing or data sheet. In addition to that we point out that any data sheet and corresponding scale drawing is no substitution for the manual.

Performance

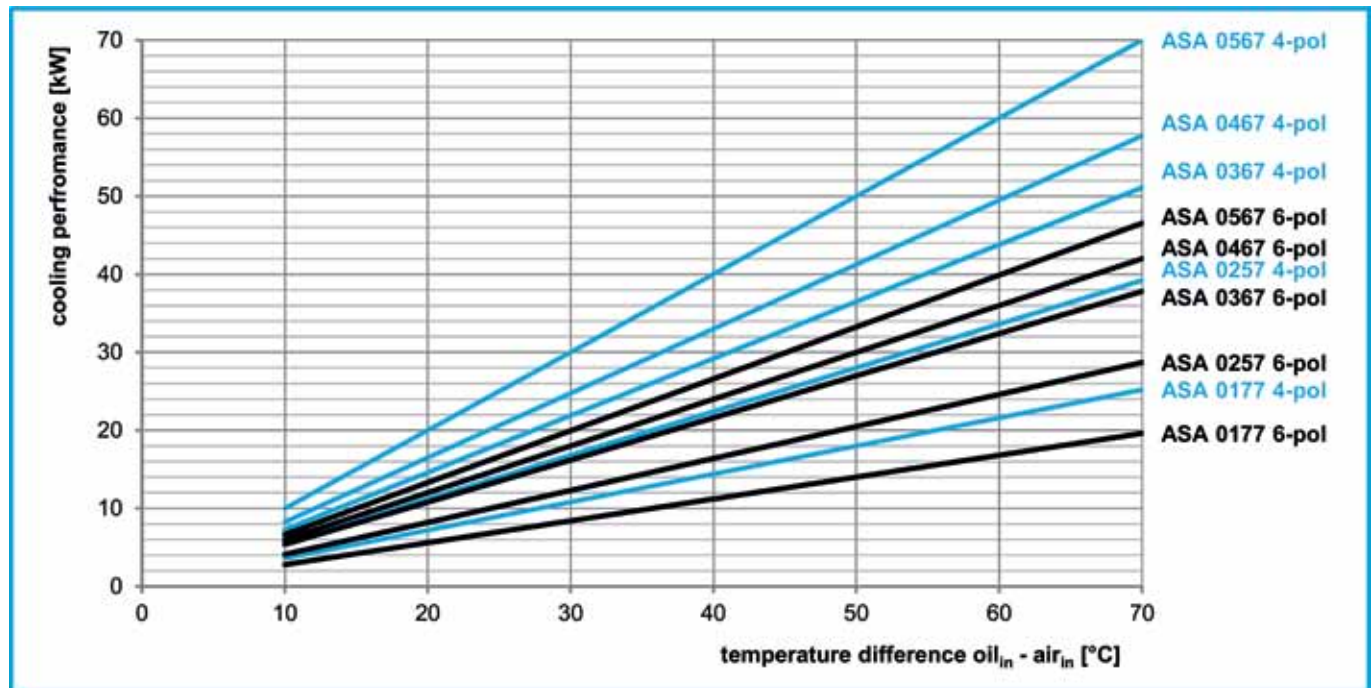

order number	description	oil flow [lpm]	max. working pressure [bar]	motor power [kW]	motor current [A]	rotation [rpm]	air flow [kg/s]	noise level [dB(A)]	weight [kg]
ASA0177AA49CC	ASA 0177 CC 4-pol	60	10	1,5	3,35	1445	0,86	74	70,7
ASA0257AA49CC	ASA 0257 CC 4-pol	60	10	1,5	3,35	1445	1,14	79	80,0
ASA0367AA49CC	ASA 0367 CC 4-pol	60	8	1,5	3,35	1445	1,42	83	90,4
ASA0467AA49CC	ASA 0467 CC 4-pol	60	7	1,5	3,35	1445	1,77	84	107,5
ASA0567AA49CC	ASA 0567 CC 4-pol	60	7	1,5	3,35	1445	1,89	84	108,1
ASA0177AA68CC	ASA 0177 CC 6-pol	40	9	0,75	1,95	955	0,55	62	55,0
ASA0257AA68CC	ASA 0257 CC 6-pol	40	9	0,75	1,95	955	0,75	68	64,0
ASA0367AA68CC	ASA 0367 CC 6-pol	40	8	0,75	1,95	955	0,94	73	74,5
ASA0467AA68CC	ASA 0467 CC 6-pol	40	7	0,75	1,95	955	1,12	74	91,5
ASA0567AA68CC	ASA 0567 CC 6-pol	40	7	0,75	1,95	955	1,21	74	93,0

The maximum suction pressure is -0,5 bar. The viscosity range is <240cSt. Motor voltage: 230/400V @ 50Hz*. The protection level is IP55.

Design

radiator material	aluminium
radiator air fin shape	wavy
pump type	screw pump
pump material (housing)	aluminium
sheet metal material	powder coated steel
suitable fluids	mineral oil



Connection (BSP 1")

ILLZASA32G32 (BSP1¼")	1 per cooler required
ILLZASA40G40 (BSP1½")	1 per cooler required

Options

temperature switch	50°C, 60°C
motor data*	alternative voltages, frequencies, protection levels, etc on request

This data sheet and the corresponding scale drawings are to be used as a general guideline and technical overview of our products. Please contact us if more exact information is needed. As we are constantly improving our products, their characteristics, dimensions and weights may also change, although we do our best to incorporate these changes continually. asa assumes no liability for any information therein, any errors, omissions, misprints, nor any direct or indirect damages, losses or costs resulting therefrom. Any cooling performances and general technical values indicated in this catalogue are measured at a test bench according to asa testing procedures or calculated, based on such tests. Due to different conditions in testing and application environments the performance may also vary by +/- 15%. Because there is no standardized testing procedure, tests used by other manufacturers could have different results. Therefore we recommend all products to be checked under the system operating conditions. This is also true for vibrations and mechanical stress as well as for pressure peaks and thermal stress and any other relevant factors. General tolerances according to DIN ISO 2768-v. General tolerances for casted parts according to EN ISO 8062-3 (DCTG 10). Tolerances for rubber parts are according to ISO 3302-1 (class M4-F+C). The tolerances of welding seams are defined by quality group D according to EN ISO 10042, if it is not specified on the actual scale drawing or data sheet. In addition to that we point out that any data sheet and corresponding scale drawing is no substitution for the manual.