

# Gerotor Pump Unit

30l/min, 230/400V 50Hz

The **asa** gerotor pump unit fulfills the requirements of a modern hydraulic system. The compactness of the gerotor pump design saves weight and space. Furthermore the solid shape of the pump is high resistant for hydraulic and mechanic impact loads. The low noise level and the easy connection complete this product to a highly flexible and reliable system for various applications. The coupling with a high quality standard motor is the optimal choice for a durable pump unit.

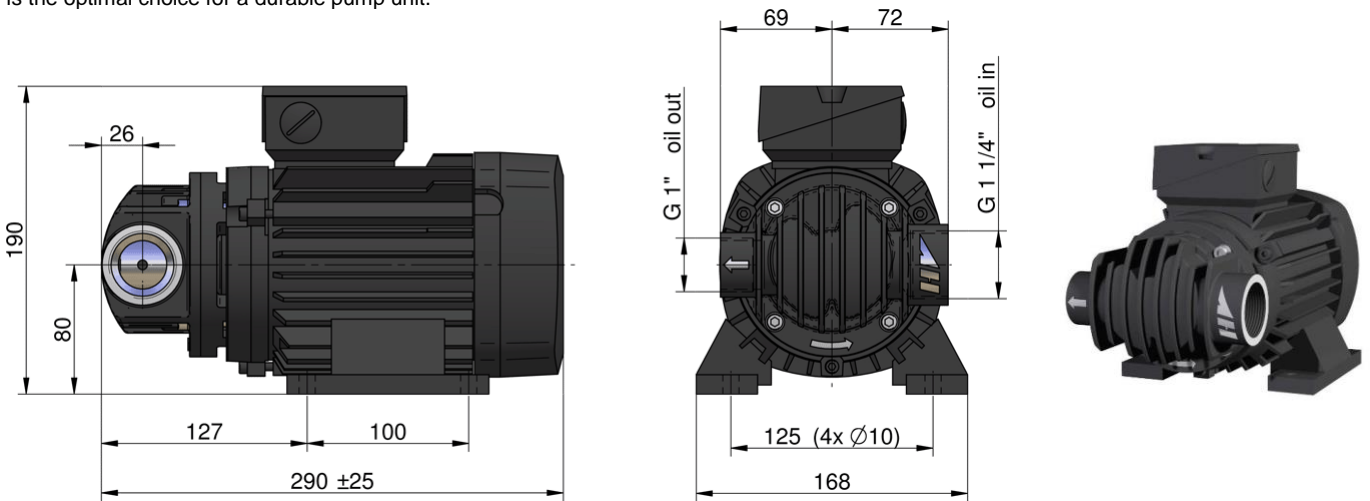

## Technical Data

description	order number	motor power [kW]	max. oil viscosity [cSt]	oil flow [l/min]	neg. pressure [bar]	poles	max. current [A]	60Hz	weight [kg]
GERO unit 100	HY0200758G	0,75	100	30	-0,4	4	2,1	•*	13,8
GERO unit 250	HY0201108G	1,10	250	30	-0,4	4	2,6	-**	16,6

\* ... 60Hz possible, 276/480 V  
\*\* ... 60Hz only on request

## Pump Characteristic

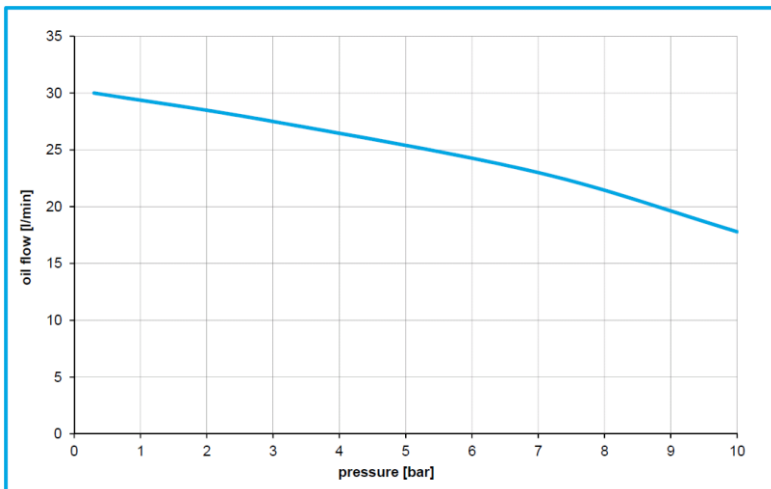

Test our optional vibration absorbers:

- noise reduction
- high durability
- high shear loads

**best practice!**



## Material

pump housing	aluminium
gerotor	sintered steel
sealings	NBR

## Options

on request	other voltages
	UL- or CSA approvals
	higher protection levels
vibration absorber M8	MDGQ403008IIK

## Working Range

ambient temperature	-20°C to +40°C
max. working pressure	10bar
max. oil temperature	80°C (100°C on request)
fluids	mineral oils

This data sheet shows a technical overview of our products. Please contact us if more exact information is needed. As we are constantly improving our products, their characteristics, dimensions and weights may also change, although we do our best to incorporate these changes continually. The information in this data sheet is intended to be used as a first general guideline only. asa assumes no liability for any information therein, any errors, omissions, misprints, nor any direct or indirect damages, losses or costs resulting therefrom. The cooling performance and the general technical values indicated in this catalogue are measured at a test bench according to asa testing procedures. Because there is no standardized testing procedure, tests used by other manufacturers could have different results. Due to different conditions in testing and application environments the cooling performance may also vary by +/- 15%. Therefore we recommend all coolers to be checked under the system operating conditions. This is also true of vibrations and mechanical stress as well as for pressure peaks and thermal stress and any other relevant factors.