

Accessories

temperature sensor

The temperature sensor requires a control unit for the control system which is available in 12V (ILLZTC12-2K) and 24V (ILLZTC24-2K). The fan speed varies according to the actual oil temperature on the sensor. This reduces the noise level of the cooler system and increases the durability of the fan motor, because it is not running at maximum speed all the time. The start up temperature of this system is 44°C and the maximum rotation of the fan is applied when the oil temperature reaches 55°C.

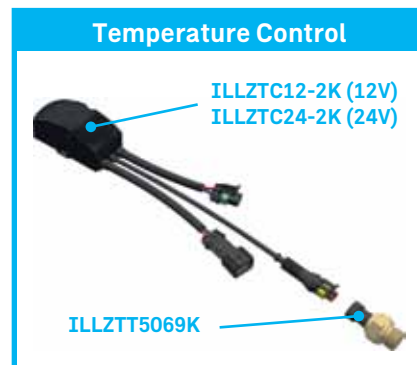
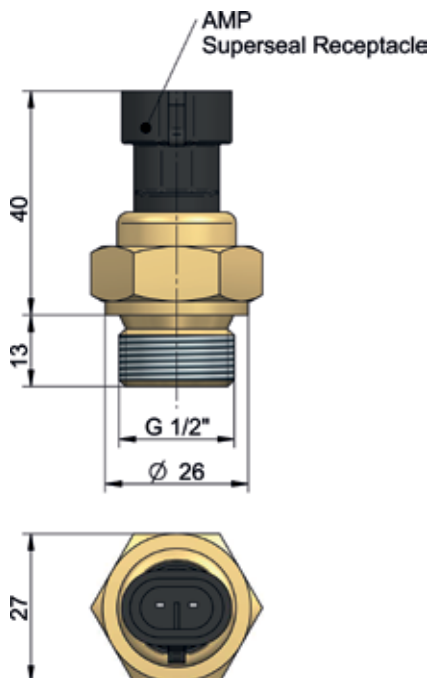

- NTC sensing
- IP 69K protection
- compact design

Technical Data

order number	description	connection	protection	weight
				[kg]
ILLZTT5069K	temperature sensor BSP ½"	AMP superseal 1.5	IP 69K	0,09

Characteristics

screw part material	brass
mounting instructions	any mounting position
maximum tightening torque	50Nm

Measurement Output

connection	AMP superseal 1.5
------------	-------------------

Ambient Conditions

oil temperature range	-20°C to +100°C
ambient temperature range	-20°C to +85°C
storage temperature range	-60°C to 110°C

Required Accessories

temperature control unit 12V DC	ILLZTC12-2K (page 43)
temperature control unit 24V DC	ILLZTC24-2K (page 43)

Combinations

12V and 24V DC coolers	LL 03L, LL 04, LL 06, LL08 / TT 05 – 25 rail / ASA 0177 – 0367
------------------------	--

This data sheet and the corresponding scale drawings are to be used as a general guideline and technical overview of our products. Please contact us if more exact information is needed. As we are constantly improving our products, their characteristics, dimensions and weights may also change, although we do our best to incorporate these changes continually. asa assumes no liability for any information therein, any errors, omissions, misprints, nor any direct or indirect damages, losses or costs resulting therefrom. Any cooling performances and general technical values indicated in this catalogue are measured at a test bench according to asa testing procedures or calculated, based on such tests. Due to different conditions in testing and application environments the performance may also vary by +/- 15%. Because there is no standardized testing procedure, tests used by other manufacturers could have different results. Therefore we recommend all products to be checked under the system operating conditions. This is also true for vibrations and mechanical stress as well as for pressure peaks and thermal stress and any other relevant factors. General tolerances according to DIN ISO 2768-v. General tolerances for casted parts according to EN ISO 8062-3 (DCTG 10). Tolerances for rubber parts are according to ISO 3302-1 (class M4-F+C). The tolerances of welding seams are defined by quality group D according to EN ISO 10042, if it is not specified on the actual scale drawing or data sheet. In addition to that we point out that any data sheet and corresponding scale drawing is no substitution for the manual.