

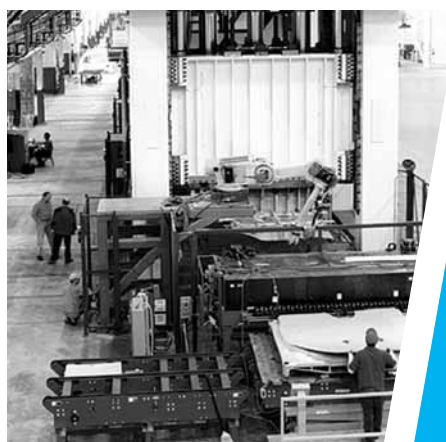

Thermal Systems

Special Ranges



**be different.
make a difference.**

Company

Who we are and what we offer

asa stands for developments, advances and innovations already at work through our customers' various mobile and stationary applications. More than 38 years experience in thermal systems, connection technology and fluid controls has made us a global leader in advanced technologies. Our experience creates progress to ensure you competitive pricing, consistent product performance and reliability.



- **worldwide availability**
- **fast reaction time**
- **technical support**



Be different. Make a difference.

Over the years, asa continually developed into a globally active systems supplier. Despite this evolution, we consciously maintained the medium sized structure of a family owned company. As a result we are able to respond quickly and flexibly to our customer's demands and promote our innovations. Our increasing product portfolio and quality targets developed asa as a brand to the next level. Thus made us create a new logo and appearance to strengthen our key values and highlight it in all our present and future markets. We are proud on looking back on almost 40 years of innovative products, but our major attitude is a the view into the future. Please check out our newest products and technologies in this catalogue and contact us if more detailed information is required.



in this catalogue...

Company

Innovation

Thermal Systems

Standard Ranges



Special Ranges

CC-Series

TT-rail

page 6–7

ASA-Series

page 8–9

W-Line

page 10

ATEX-Series

page 11

AS-Series

page 12–13

MC-Series

page 14

Accessories

page 15–19

H-Ranges



Connection Technology



Fluid Controls



R & D Services



get in contact for this catalogue

Innovation

Customize our products to your requirements.

Our innovations affect not only the efficiency of the function, it offers add on values for the customer as well.

Our design philosophy is to use our patented systems to integrate various functions of a hydraulic circuit with standard modules to a customized product. This merges asa's well known flexible systems and engineering capabilities to gain real cost and space reduction, through simplification of parts and variable functions, to any application.

The system integration is defined by the required functions based on a cooling station, docking one or more variable sets.

- **patented technology**
- **protecting your market**
- **add on values**

select basic module...



...add on values...



connect

mount



control

bypass



protect

integrate





**discover the
customized standard**

CC Series

TT rail 20/30lpm



General Data And Details

The oil / air coolers of our CC series are autonomous cooling systems with an integrated circulation pump. They work as a separate cooling unit or as a filter cooling unit with an adequate filter. The benefits of such circulation coolers are a constant cooling performance and a higher durability, because there are no pressure vibrations or peaks in the cooler unit.

Conditions of use:

Maximum oil temperature: 80°C, maximum air temperature: 50°C. Motors can be used up to an altitude of 1.500m. For other conditions of use please contact our engineers.

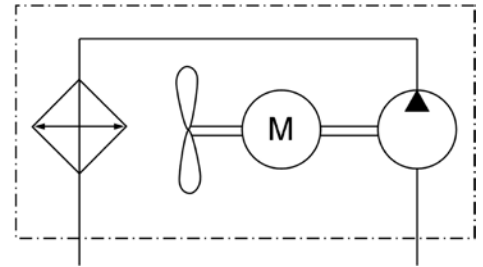

Connection asa rail

The **asa rail** system is the first worldwide flexible mounting and connection system for air blast heat exchangers. It gives you the free choice of the connector direction through turnable ports. The rail slots in the radiator are the frame structure not only for connecting the ports, also for various possible mounting arrangements such as bypass systems, mounting of the cooler to aggregates, measurement devices and much more. Please contact us to discover the huge potential of this system for your application.

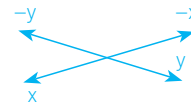

Scale Drawing

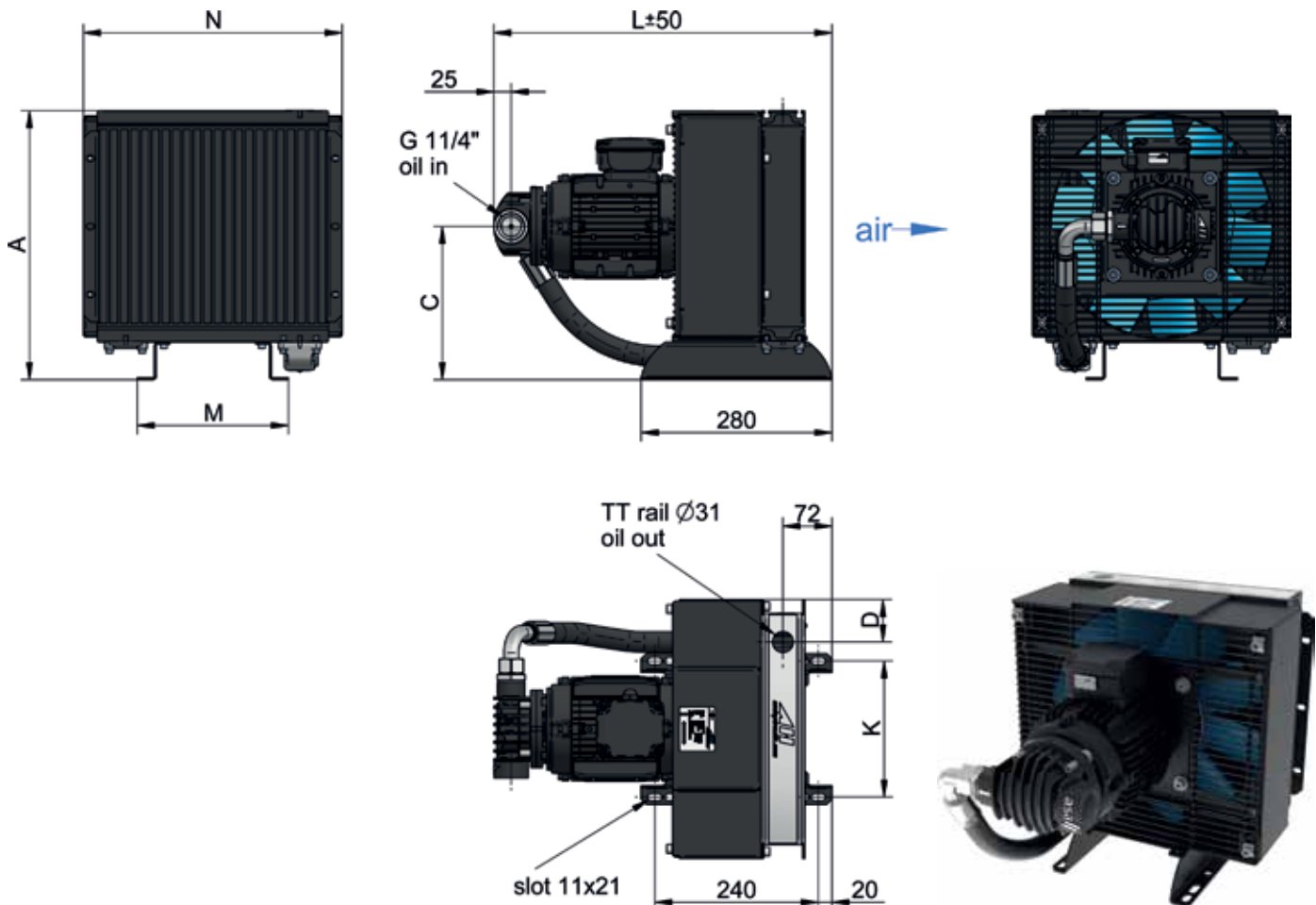

This data sheet and the corresponding scale drawings are to be used as a general guideline and technical overview of our products. Please contact us if more exact information is needed. As we are constantly improving our products, their characteristics, dimensions and weights may also change, although we do our best to incorporate these changes continually. asa assumes no liability for any information therein, any errors, omissions, misprints, nor any direct or indirect damages, losses or costs resulting therefrom. Any cooling performances and general technical values indicated in this catalogue are measured at a test bench according to asa testing procedures or calculated, based on such tests. Due to different conditions in testing and application environments the performance may also vary by +/- 15%. Because there is no standardized testing procedure, tests used by other manufacturers could have different results. Therefore we recommend all products to be checked under the system operating conditions. This is also true for vibrations and mechanical stress as well as for pressure peaks and thermal stress and any other relevant factors. General tolerances according to DIN ISO 2768-v. General tolerances for casted parts according EN ISO 8062-3 (DCTG 10). Tolerances for rubber parts are according to ISO 3302-1 (class M4-F+C). The tolerances of welding seams are defined by quality group D according to EN ISO 10042, if it is not specified on the actual scale drawing or data sheet. In addition to that we point out that any data sheet and corresponding scale drawing is no substitution for the manual.

Performance

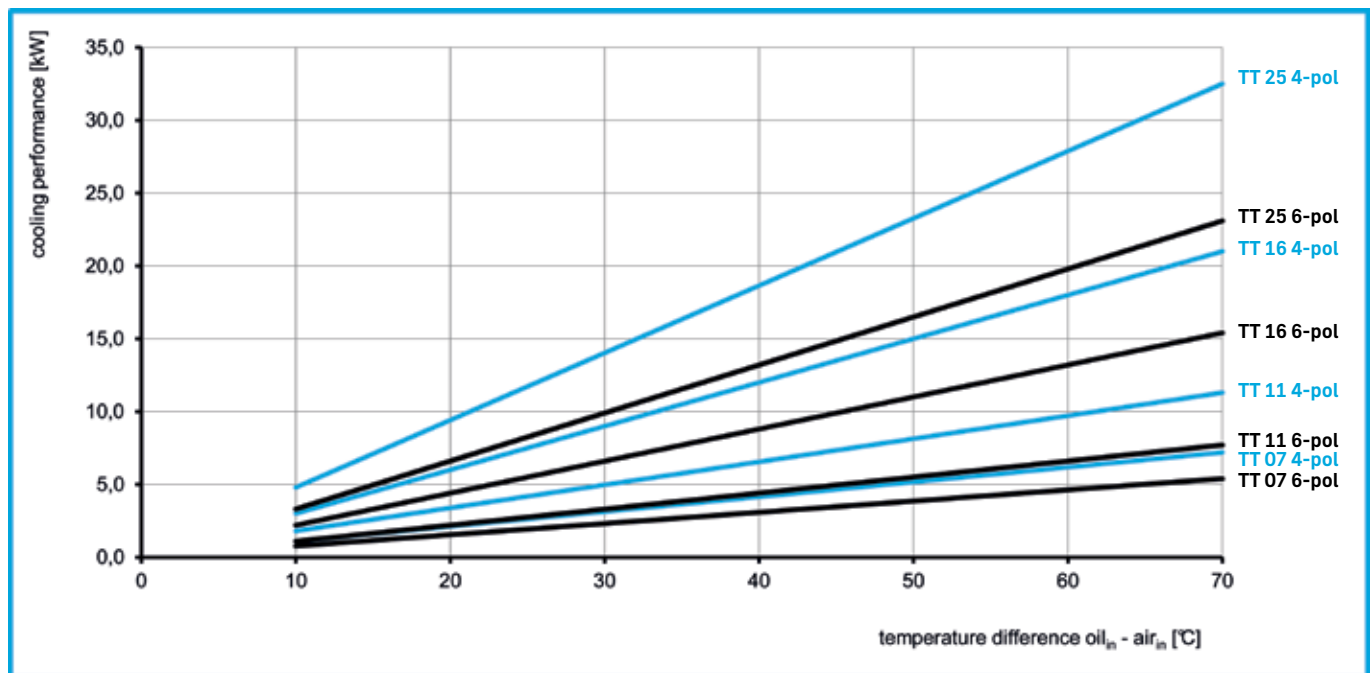

Technical Data

order number	description	oil flow	max. working pressure	motor power	motor current	rotation	air flow	noise level	weight	A	C	D	K	L	M	N
		[lpm]	[bar]	[kW]	[A]	[rpm]	[kg/s]	[dB(A)]	[kg]	[mm]	[mm]	[mm]	[mm]	[mm]	[mm]	[mm]
ASATT07RA47CC	TT 07 rail CC 4-pol	30	10	0,75	1,7	1445	0,19	65	24,4	355	205	72	135	493	157	320
ASATT11RA47CC	TT 11 rail CC 4-pol	30	10	0,75	1,7	1445	0,48	68	28,3	395	225	62	200	495	222	380
ASATT16RA47CC	TT 16 rail CC 4-pol	30	9	0,75	1,7	1445	0,64	74	35,8	520	288	66	200	511	222	460
ASATT25RA47CC	TT 25 rail CC 4-pol	30	6	0,75	1,7	1445	2,00	79	44,4	660	358	68	300	511	322	558
ASATT07RA66CC	TT 07 rail CC 6-pol	20	9	0,37	1,17	935	0,13	57	24,5	355	205	72	135	493	157	320
ASATT11RA66CC	TT 11 rail CC 6-pol	20	8	0,37	1,17	935	0,32	58	28,4	395	225	62	200	495	222	380
ASATT16RA66CC	TT 16 rail CC 6-pol	20	8	0,37	1,17	935	0,44	65	35,9	520	288	66	200	511	222	460
ASATT25RA66CC	TT 25 rail CC 6-pol	20	6	0,37	1,17	935	1,30	68	44,5	660	358	68	300	511	322	558

The maximum suction pressure is -0,4 bar. The viscosity range is <100cSt. Motor voltage: 230/400V @ 50Hz*. The protection level is IP55.

Design

radiator material	aluminium
radiator air fin shape	wavy
pump type	gerotor
pump material (housing)	aluminium
sheet metal material	powder coated steel
suitable fluids	mineral oil

Connection (BSP 1")

ILLZATT53G25K	requires 1pc per cooler
---------------	-------------------------

Options

asa rail connector	BSP 1 ¼"
temperature switch	50°C, 60°C
Rail filter	integrated spin on filter (page 15)
motor data*	alternative voltages, frequencies, protection levels, etc on request



This data sheet and the corresponding scale drawings are to be used as a general guideline and technical overview of our products. Please contact us if more exact information is needed. As we are constantly improving our products, their characteristics, dimensions and weights may also change, although we do our best to incorporate these changes continually. asa assumes no liability for any information therein, any errors, omissions, misprints, nor any direct or indirect damages, losses or costs resulting therefrom. Any cooling performances and general technical values indicated in this catalogue are measured at a test bench according to asa testing procedures or calculated, based on such tests. Due to different conditions in testing and application environments the performance may also vary by +/- 15%. Because there is no standardized testing procedure, tests used by other manufacturers could have different results. Therefore we recommend all products to be checked under the system operating conditions. This is also true for vibrations and mechanical stress as well as for pressure peaks and thermal stress and any other relevant factors. General tolerances according to DIN ISO 2768-v. General tolerances for casted parts according EN ISO 8062-3 (DCTG 10). Tolerances for rubber parts are according to ISO 3302-1 (class M4-F+C). The tolerances of welding seams are defined by quality group D according to EN ISO 10042, if it is not specified on the actual scale drawing or data sheet. In addition to that we point out that any data sheet and corresponding scale drawing is no substitution for the manual.

CC Series

ASA Series 40/60lpm



General Data And Details

The oil / air coolers of our CC series are autonomous cooling systems with an integrated circulation pump. They work as a separate cooling unit or as a filter cooling unit with an adequate filter. The benefits of such circulation coolers are a constant cooling performance and a higher durability, because there are no pressure vibrations or peaks in the cooler unit.

Conditions of use:

Maximum oil temperature: 80°C, maximum air temperature: 50°C. Motors can be used up to an altitude of 1.500m. For other conditions of use please contact our engineers.

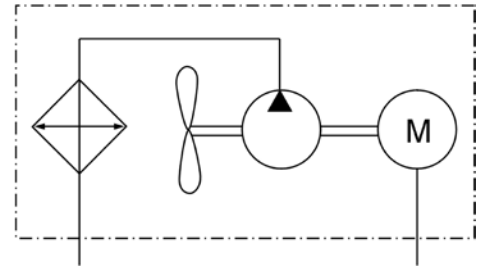

Connection asa uc

The **AUC (asa universal connector)** system was the first worldwide flexible connection system for air blast heat exchangers. It gives you the free choice of the connector direction through turnable ports in 3 directions. Also the dimension of the ports can be varied with optional types. Please contact us to discover the huge potential of this system for your application.

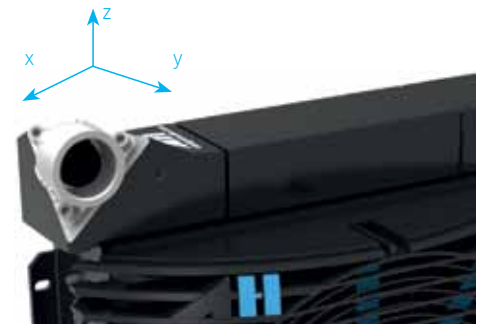

Scale Drawing

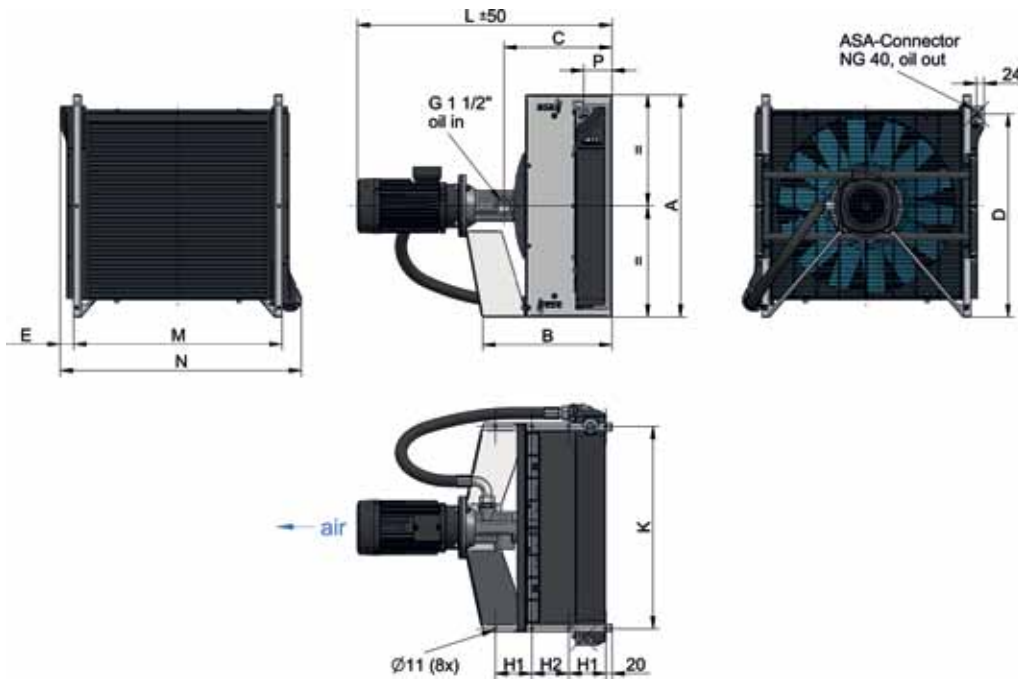

order number	description	A	B	C	D	E	H1	H2	K	L	M	N	P
		[mm]	[mm]	[mm]	[mm]	[mm]	[mm]	[mm]	[mm]	[mm]	[mm]	[mm]	[mm]
ASA0177AA49CC	ASA 0177 CC 4-pol	530	400	331	471	60	120	90	442	807	462	601	89
ASA0257AA49CC	ASA 0257 CC 4-pol	635	410	341	568	60	110	110	542	817	562	701	93
ASA0367AA49CC	ASA 0367 CC 4-pol	720	420	351	658	46	120	120	656	827	676	781	92
ASA0467AA49CC	ASA 0467 CC 4-pol	785	426	367	727	40	125	125	738	843	758	856	94
ASA0567AA49CC	ASA 0567 CC 4-pol	860	416	361	802	43	125	125	806	837	826	931	94
ASA0177AA68CC	ASA 0177 CC 6-pol	530	400	331	471	60	120	90	442	807	462	601	89
ASA0257AA68CC	ASA 0257 CC 6-pol	635	410	341	568	60	110	110	542	817	562	701	93
ASA0367AA68CC	ASA 0367 CC 6-pol	720	420	351	658	46	120	120	656	827	676	781	93
ASA0467AA68CC	ASA 0467 CC 6-pol	785	426	367	727	40	125	125	738	843	758	856	92
ASA0567AA68CC	ASA 0567 CC 6-pol	860	416	361	802	43	125	125	806	837	826	931	94

This data sheet and the corresponding scale drawings are to be used as a general guideline and technical overview of our products. Please contact us if more exact information is needed. As we are constantly improving our products, their characteristics, dimensions and weights may also change, although we do our best to incorporate these changes continually. asa assumes no liability for any information therein, any errors, omissions, misprints, nor any direct or indirect damages, losses or costs resulting therefrom. Any cooling performances and general technical values indicated in this catalogue are measured at a test bench according to asa testing procedures or calculated, based on such tests. Due to different conditions in testing and application environments the performance may also vary by +/- 15%. Because there is no standardized testing procedure, tests used by other manufacturers could have different results. Therefore we recommend all products to be checked under the system operating conditions. This is also true for vibrations and mechanical stress as well as for pressure peaks and thermal stress and any other relevant factors. General tolerances according to DIN ISO 2768-v. General tolerances for casted parts according to EN ISO 8062-3 (DCTG 10). Tolerances for rubber parts are according to ISO 3302-1 (class M4-F+C). The tolerances of welding seams are defined by quality group D according to EN ISO 10042, if it is not specified on the actual scale drawing or data sheet. In addition to that we point out that any data sheet and corresponding scale drawing is no substitution for the manual.

Performance

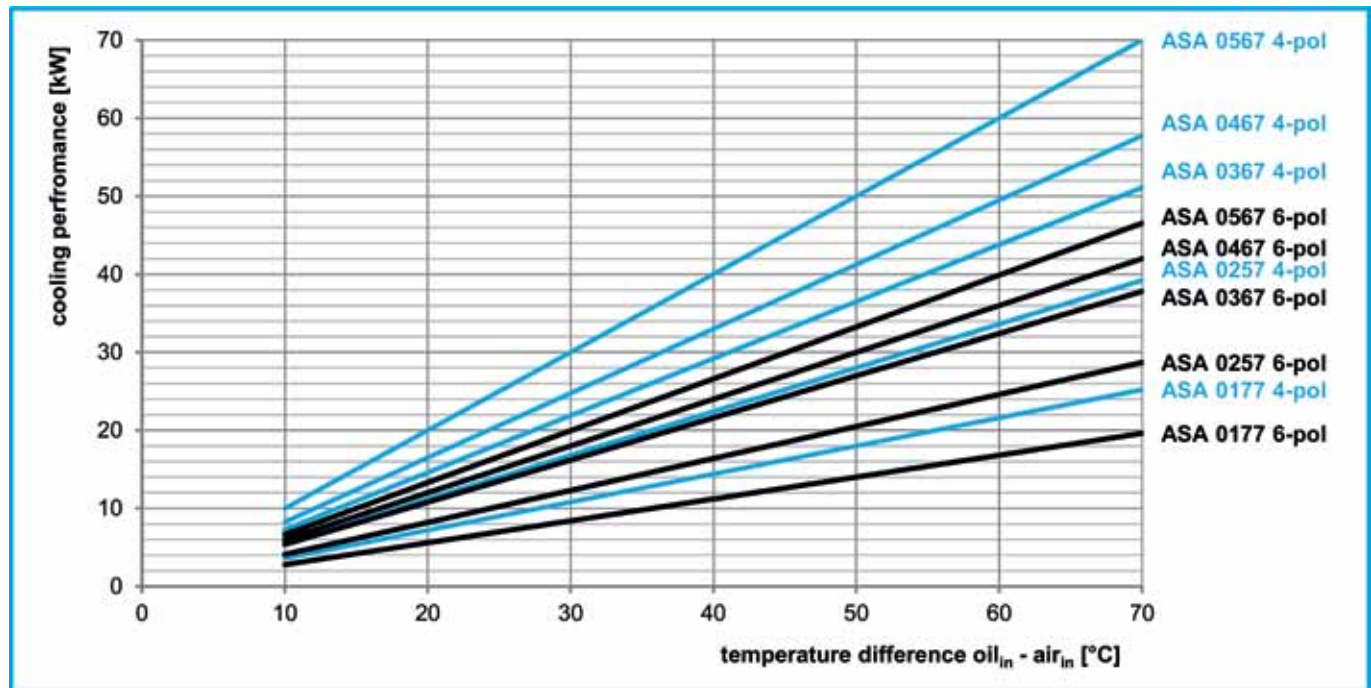

order number	description	oil flow [lpm]	max. working pressure [bar]	motor power [kW]	motor current [A]	rotation [rpm]	air flow [kg/s]	noise level [dB(A)]	weight [kg]
ASA0177AA49CC	ASA 0177 CC 4-pol	60	10	1,5	3,35	1445	0,86	74	70,7
ASA0257AA49CC	ASA 0257 CC 4-pol	60	10	1,5	3,35	1445	1,14	79	80,0
ASA0367AA49CC	ASA 0367 CC 4-pol	60	8	1,5	3,35	1445	1,42	83	90,4
ASA0467AA49CC	ASA 0467 CC 4-pol	60	7	1,5	3,35	1445	1,77	84	107,5
ASA0567AA49CC	ASA 0567 CC 4-pol	60	7	1,5	3,35	1445	1,89	84	108,1
ASA0177AA68CC	ASA 0177 CC 6-pol	40	9	0,75	1,95	955	0,55	62	55,0
ASA0257AA68CC	ASA 0257 CC 6-pol	40	9	0,75	1,95	955	0,75	68	64,0
ASA0367AA68CC	ASA 0367 CC 6-pol	40	8	0,75	1,95	955	0,94	73	74,5
ASA0467AA68CC	ASA 0467 CC 6-pol	40	7	0,75	1,95	955	1,12	74	91,5
ASA0567AA68CC	ASA 0567 CC 6-pol	40	7	0,75	1,95	955	1,21	74	93,0

The maximum suction pressure is -0,5 bar. The viscosity range is <240cSt. Motor voltage: 230/400V @ 50Hz*. The protection level is IP55.

Design

radiator material	aluminium
radiator air fin shape	wavy
pump type	screw pump
pump material (housing)	aluminium
sheet metal material	powder coated steel
suitable fluids	mineral oil



Connection (BSP 1")

ILLZASA32G32 (BSP1¼")	1 per cooler required
ILLZASA40G40 (BSP1½")	1 per cooler required

Options

temperature switch	50°C, 60°C
motor data*	alternative voltages, frequencies, protection levels, etc on request

This data sheet and the corresponding scale drawings are to be used as a general guideline and technical overview of our products. Please contact us if more exact information is needed. As we are constantly improving our products, their characteristics, dimensions and weights may also change, although we do our best to incorporate these changes continually. asa assumes no liability for any information therein, any errors, omissions, misprints, nor any direct or indirect damages, losses or costs resulting therefrom. Any cooling performances and general technical values indicated in this catalogue are measured at a test bench according to asa testing procedures or calculated, based on such tests. Due to different conditions in testing and application environments the performance may also vary by +/- 15%. Because there is no standardized testing procedure, tests used by other manufacturers could have different results. Therefore we recommend all products to be checked under the system operating conditions. This is also true for vibrations and mechanical stress as well as for pressure peaks and thermal stress and any other relevant factors. General tolerances according to DIN ISO 2768-v. General tolerances for casted parts according to EN ISO 8062-3 (DCTG 10). Tolerances for rubber parts are according to ISO 3302-1 (class M4-F+C). The tolerances of welding seams are defined by quality group D according to EN ISO 10042, if it is not specified on the actual scale drawing or data sheet. In addition to that we point out that any data sheet and corresponding scale drawing is no substitution for the manual.

W-Line Series

Oil/air coolers for aggressive environments



General Data and Details

Our W series coolers are designed for high duration at aggressive environments as found in offshore, marine and coastal applications. More than 38 years in heat transfer equipment has made us a global leader in advanced technologies. This ensures you competitive pricing, consistent product performance and reliability.

The corrosion resistance of this series is successfully verified by salt spray tests according DIN EN ISO 9227. This is comparable to C5-M short of ISO 12944. We allow a degree of Ri3 according ISO 4628-3.

The available types are equipped with our well established asa universal connector system. Please check out the flexibility and benefits of this system at www.asahydraulik.com or contact us at support@asahydraulik.com.



Performance overview

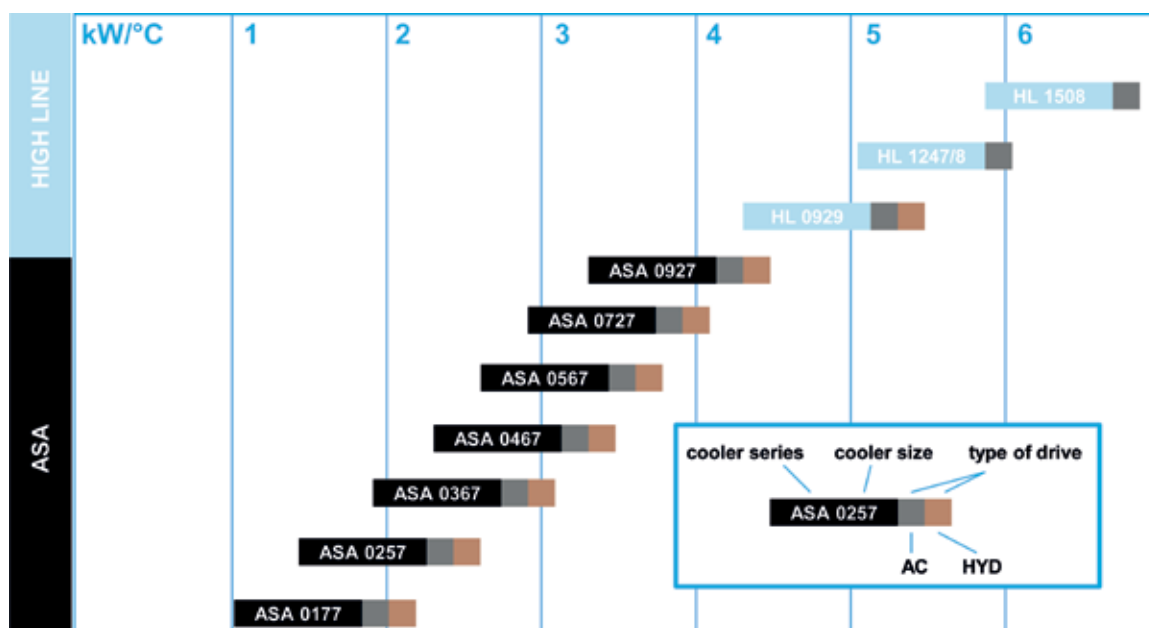

Selection / Available Types

ASA series AC and Hydraulic	0177, 0257, 0367, 0467, 0567, 0727, 0927
HighLine series AC	HL 0929, 1247, 1248, 1508

Options / Accessories

The coolers can be customized by various options like internal bypass, temperature switches, asa universal connectors, etc. Also available are different voltages and frequencies for the electric motors. Hydraulic driven coolers can also be supplied with these specifications. The hydraulic motor has no special protection due to the complex and various applications. Please contact us for detailed information.



This data sheet and the corresponding scale drawings are to be used as a general guideline and technical overview of our products. Please contact us if more exact information is needed. As we are constantly improving our products, their characteristics, dimensions and weights may also change, although we do our best to incorporate these changes continually. asa assumes no liability for any information therein, any errors, omissions, misprints, nor any direct or indirect damages, losses or costs resulting therefrom. Any cooling performances and general technical values indicated in this catalogue are measured at a test bench according to asa testing procedures or calculated, based on such tests. Due to different conditions in testing and application environments the performance may also vary by +/- 15%. Because there is no standardized testing procedure, tests used by other manufacturers could have different results. Therefore we recommend all products to be checked under the system operating conditions. This is also true for vibrations and mechanical stress as well as for pressure peaks and thermal stress and any other relevant factors. General tolerances according to DIN ISO 2768-v. General tolerances for casted parts according EN ISO 8062-3 (DCTG 10). Tolerances for rubber parts are according to ISO 3302-1 (Class M4-F+C). The tolerances of welding seams are defined by quality group D according to EN ISO 10042, if it is not specified on the actual scale drawing or data sheet. In addition to that we point out that any data sheet and corresponding scale drawing is no substitution for the manual.

ATEX Series

Manufactured according to ATEX standard



General Data And Information

asa oil/air coolers are available for atex zone 1, 2 and 22. Therefore the coolers are certified for categories 2G and 3. ATEX certified **asa** coolers belong to cluster II. The table below shows the specifications of the zones and categories.

The shown cooler models are available with AC drive, but also with hydraulic motor drive. The ATEX coolers are equipped either with our well established **asa** universal connectors or the new **asa** rail system. Please check out the flexibility and benefits of this system at www.asahydraulik.com or contact us for detailed information on support@asahydraulik.com.



zone		category
	gas (G)	dust (D)
1	zone 1: Is an explosive atmosphere consisting of a mixture with air of flammable substances like gas, vapour or mist occurring in normal operation, occasionally.	2
2	zone 2: A place in which an explosive atmosphere consisting of a mixture with are of flammable substances as a gas, vapour or mist is not likely to occur in normal operation but, if it does occur, will persist for a short period only.	zone 22: A place in which an explosive atmosphere as a cloud of combustible dust in the air is not likely to occur in normal operation but, if it does occur, will persist for a short period.

Certification	
Our ATEX marking according RL 94/9/EG is CE Ex II 2G EEx c IIB T4	TÜV Austria Notified Body 0408 TÜV AUSTRIA

Selection / Available Types

TT rail series	TT 07, 11, 16, 25
ASA series	ASA 0177, 0257, 0367, 0467, 0567, 0727, 0927
HighLine series	HL 0929, 1247, 1248, 1508

Please select the ATEX series coolers like our standard coolers with our online calculation program or contact us. We are happy to support you to select the optimal product and available accessories. The listed standard sizes are available with AC and hydraulic drive.

Options / Accessories

The coolers can be customized by various options like internal bypass, mounting arrangements, **asa** universal connectors, etc. Our standard voltage on ATEX AC motors is 230/400V at 50Hz. Other protection levels, voltages and frequencies are available on request. Please contact us for details or get further information at www.asahydraulik.com or support@asahydraulik.com.



This data sheet and the corresponding scale drawings are to be used as a general guideline and technical overview of our products. Please contact us if more exact information is needed. As we are constantly improving our products, their characteristics, dimensions and weights may also change, although we do our best to incorporate these changes continually. asa assumes no liability for any information therein, any errors, omissions, misprints, nor any direct or indirect damages, losses or costs resulting therefrom. Any cooling performances and general technical values indicated in this catalogue are measured at a test bench according to asa testing procedures or calculated, based on such tests. Due to different conditions in testing and application environments the performance may also vary by +/- 15%. Because there is no standardized testing procedure, tests used by other manufacturers could have different results. Therefore we recommend all products to be checked under the system operating conditions. This is also true for vibrations and mechanical stress as well as for pressure peaks and thermal stress and any other relevant factors. General tolerances according to DIN ISO 2768-v. General tolerances for casted parts according EN ISO 8062-3 (DCTG 10). Tolerances for rubber parts are according to ISO 3302-1 (class M4-F+C). The tolerances of welding seams are defined by quality group D according to EN ISO 10042, if it is not specified on the actual scale drawing or data sheet. In addition to that we point out that any data sheet and corresponding scale drawing is no substitution for the manual.

AS Series

AS300 AC

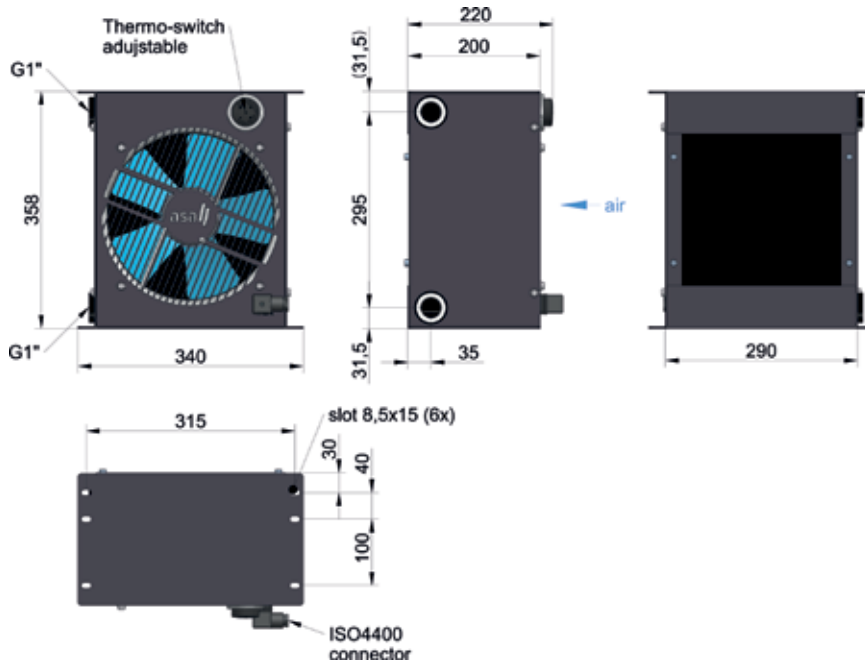

Electric Connection:

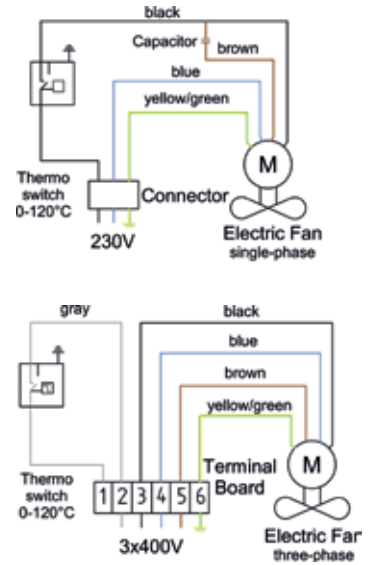

Technical Data

order number	description	current	motor power	protection level	rotation	air flow	noise level	weight
		[A]	[kW]		[rpm]	[kg/s]	[db(A)]	[kg]
ILLC00603B00	AS300 230V 2-pol AC	0,35	0,09	IP 44	2530	0,33	69	12,9
ILLC00604B00	AS300 3 x 400V 2-pol AC	0,17	0,08	IP 44	2650	0,33	69	12,9

Performance

The performances in this catalogue have been verified on a test bench according to asa test procedures. The parameters and test conditions are equal to competitor and the corresponding asa product.

specific cooling performance

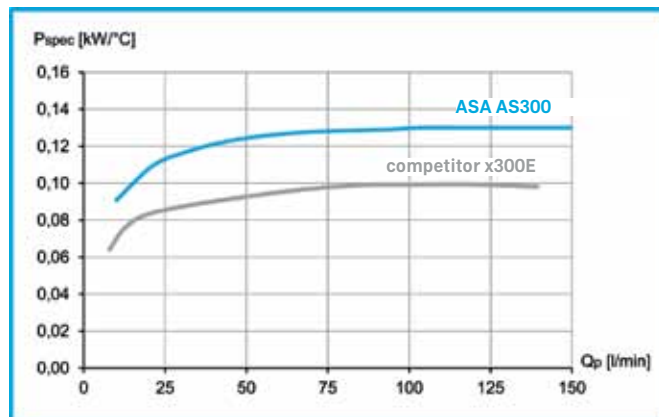

pressure drop at 30cSt

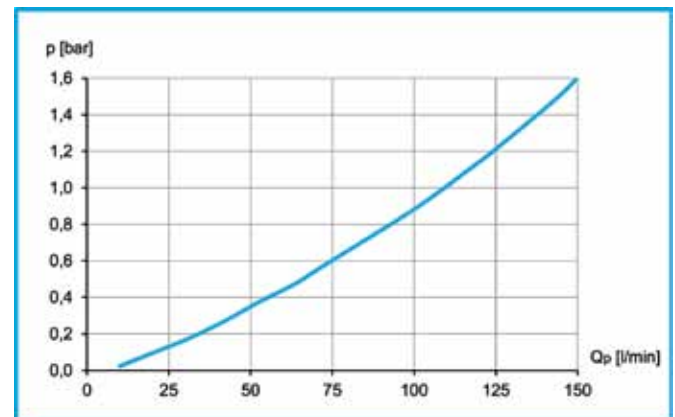

Radiator

material:	aluminium
working temperature range:	-20°C to +100°C (oil temperature)
air fin shape:	wavy
working pressure:	26 bar (static)



This data sheet and the corresponding scale drawings are to be used as a general guideline and technical overview of our products. Please contact us if more exact information is needed. As we are constantly improving our products, their characteristics, dimensions and weights may also change, although we do our best to incorporate these changes continually. asa assumes no liability for any information therein, any errors, omissions, misprints, nor any direct or indirect damages, losses or costs resulting therefrom. Any cooling performances and general technical values indicated in this catalogue are measured at a test bench according to asa testing procedures or calculated, based on such tests. Due to different conditions in testing and application environments the performance may also vary by +/- 15%. Because there is no standardized testing procedure, tests used by other manufacturers could have different results. Therefore we recommend all products to be checked under the system operating conditions. This is also true for vibrations and mechanical stress as well as for pressure peaks and thermal stress and any other relevant factors. General tolerances according to DIN ISO 2768-v. General tolerances for casted parts according to EN ISO 8062-3 (DCTG 10). Tolerances for rubber parts are according to ISO 3302-1 (class M4-F+C). The tolerances of welding seams are defined by quality group D according to EN ISO 10042, if it is not specified on the actual scale drawing or data sheet. In addition to that we point out that any data sheet and corresponding scale drawing is no substitution for the manual.

AS Series

AS300-2 AC

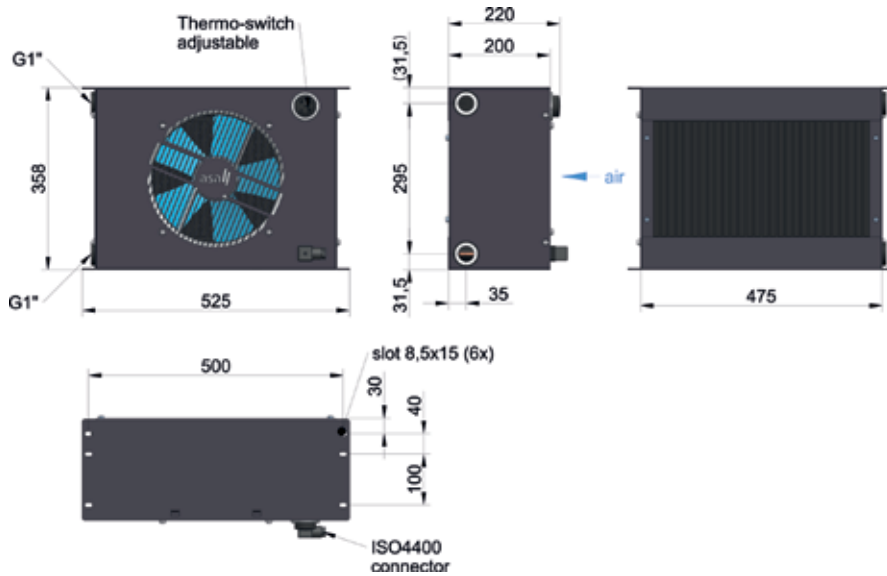

Electric Connection:

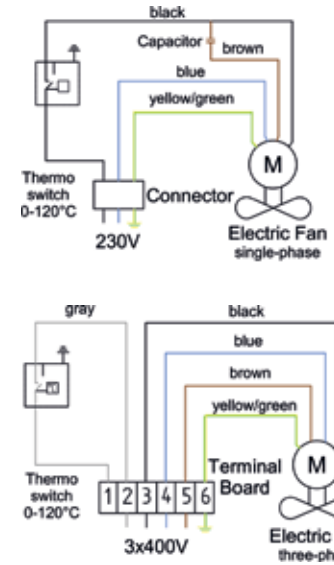

Technical Data

order number	description	current	motor power	protection level	rotation	air flow	noise level	weight
		[A]	[kW]		[rpm]	[kg/s]	[db(A)]	[kg]
ILLCO1003B00	AS300-2 230V 2-pol AC	0,35	0,09	IP 44	2530	0,41	68	17,9
ILLCO1004B00	AS300-2 3 × 400V 2-pol AC	0,17	0,08	IP 44	2650	0,41	68	17,9

Performance

The performances in this catalogue have been verified on a test bench according to asa test procedures. The parameters and test conditions are equal to competitor and the corresponding asa product.

specific cooling performance

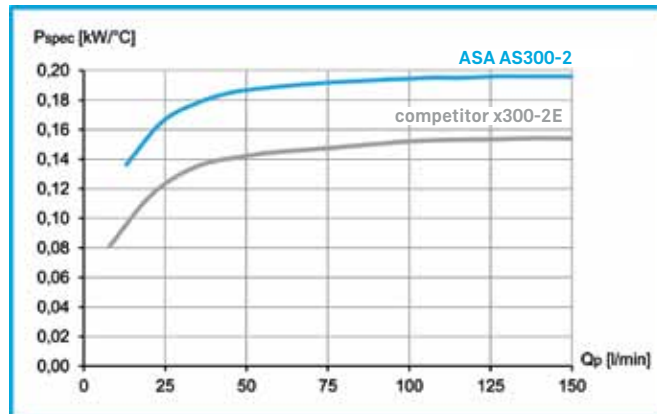

pressure drop at 30cSt

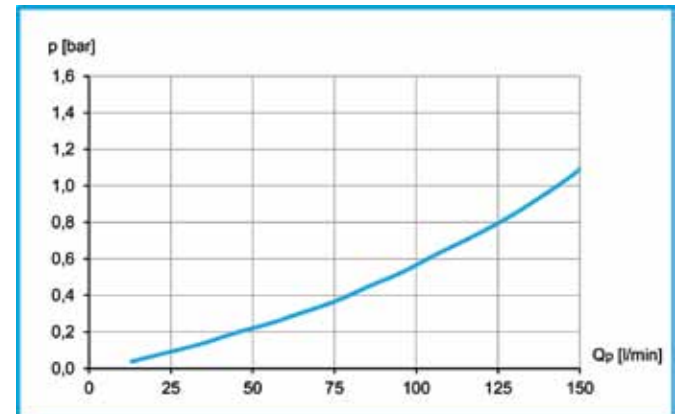

Radiator

material:	aluminium
working temperature range:	-20°C to +100°C (oil temperature)
air fin shape:	wavy
working pressure:	26 bar (static)



This data sheet and the corresponding scale drawings are to be used as a general guideline and technical overview of our products. Please contact us if more exact information is needed. As we are constantly improving our products, their characteristics, dimensions and weights may also change, although we do our best to incorporate these changes continually. asa assumes no liability for any information therein, any errors, omissions, misprints, nor any direct or indirect damages, losses or costs resulting therefrom. Any cooling performances and general technical values indicated in this catalogue are measured at a test bench according to asa testing procedures or calculated, based on such tests. Due to different conditions in testing and application environments the performance may also vary by +/- 15%. Because there is no standardized testing procedure, tests used by other manufacturers could have different results. Therefore we recommend all products to be checked under the system operating conditions. This is also true for vibrations and mechanical stress as well as for pressure peaks and thermal stress and any other relevant factors. General tolerances according to DIN ISO 2768-v. General tolerances for casted parts according to EN ISO 8062-3 (DCTG 10). Tolerances for rubber parts are according to ISO 3302-1 (class M4-F+C). The tolerances of welding seams are defined by quality group D according to EN ISO 10042, if it is not specified on the actual scale drawing or data sheet. In addition to that we point out that any data sheet and corresponding scale drawing is no substitution for the manual.

MC Series

Motor Cooling Series

Customized to your applications

Apart from the actual application parameters of the fan drive, ambient conditions and scope of delivery, we offer customized cooler solutions for many types of fluids. Please contact us with your specific requirements and use our benefits regarding consultation and most realistic verification.

type of media / applications

charge air / intercoolers
fuels (Diesel, ...)
Gear oil / transmission cooling
hydraulic oil
lubrication oil
water / glycol / motor cooling

available features

low fouling air fins
internal bypass
expansion tanks
double fan solutions
side by side coolers



your advantages:

- ✓ project management
- ✓ calculation and simulation
- ✓ verification on test bench
- ✓ procurement option system
- ✓ approved quality

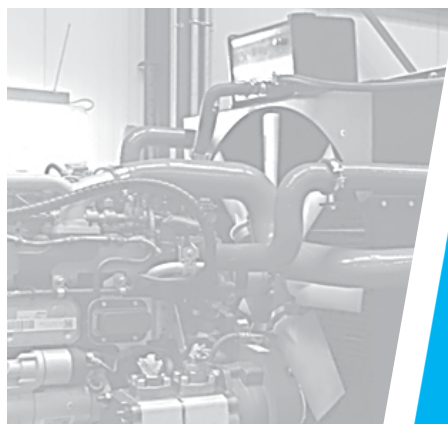

Accessories

System for Rail Series



The H-Set is an optional system to integrate another hydraulic set to the asa rail system. The H-Set currently offers 2 sizes of kits to mount a spin on filter to the cooler application. This is a very compact and cost efficient integration. This system can also be combined with various other filters or the shown configurations. Contact us for further options and assistance to select the optimal product for you.

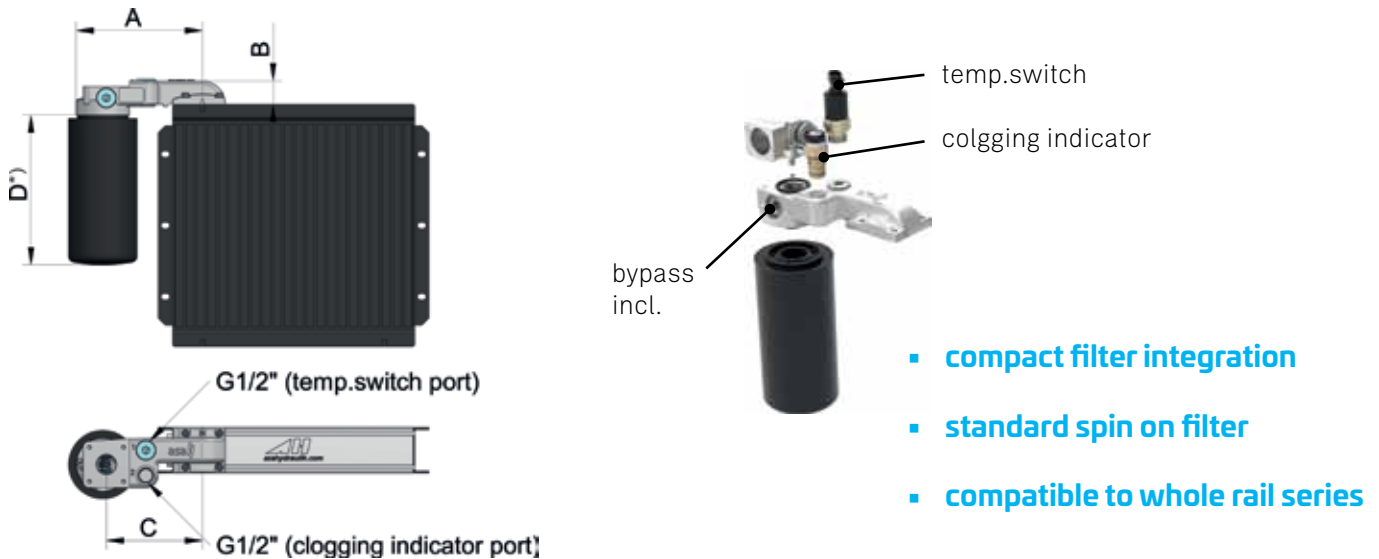

*) depending on the make of the filter element

Dimension

order number	description	filter rating	working pressure	bypass incl.	spin on port	A	B	C	D
		[μm]	[bar]	[bar]	[BSP]	[mm]	[mm]	[mm]	[mm]
ILLZRF11G2010	Spin on filter kit rail 10 μm , 60lpm	10	10	2	3/4"	177,5	33	135	146
ILLZRF11G2025	Spin on filter kit rail 25 μm , 60lpm	25	10	2	3/4"	177,5	33	135	146
ILLZRF12G2010	Spin on filter kit rail 10 μm , 100lpm	10	10	2	3/4"	177,5	33	135	191
ILLZRF12G2025	Spin on filter kit rail 25 μm , 100lpm	25	10	2	3/4"	177,5	33	135	191

Rail-filter Block

material:	aluminium
working temperature range:	-20°C to +100°C (oil temperature)*
Sealing to rail flange:	o-ring NBR
bypass:	incl.2 bar standard setting

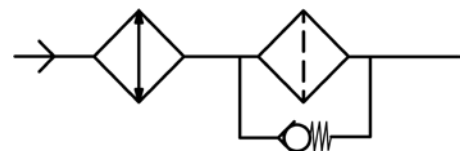

Hydraulic Connection

compatible to	any rail system cooler
---------------	------------------------

Application

main application	are offline circuits, lubrication, cooling and filtration circuits
oil flow	from cooler to filter

Options

temperature switches	ILLZTH5069K, ILLZTH4765K, ILLZTH6065K
clogging indicator/ indication pressure 1,5 bar	electric: HFZVEG15 N.O. & N.C. contact optical: HFZVOG15



* ...the indicated temperature is the maximum inlet temperature for the cooler radiator. Depending on the sealings in use, the application needs appropriate checking.

This data sheet and the corresponding scale drawings are to be used as a general guideline and technical overview of our products. Please contact us if more exact information is needed. As we are constantly improving our products, their characteristics, dimensions and weights may also change, although we do our best to incorporate these changes continually. asa assumes no liability for any information therein, any errors, omissions, misprints, nor any direct or indirect damages, losses or costs resulting therefrom. Any cooling performances and general technical values indicated in this catalogue are measured at a test bench according to asa testing procedures or calculated, based on such tests. Due to different conditions in testing and application environments the performance may also vary by +/- 15%. Because there is no standardized testing procedure, tests used by other manufacturers could have different results. Therefore we recommend all products to be checked under the system operating conditions. This is also true for vibrations and mechanical stress as well as for pressure peaks and thermal stress and any other relevant factors. General tolerances according to DIN ISO 2768-v. General tolerances for casted parts according EN ISO 8062-3 (DCTG 10). Tolerances for rubber parts are according to ISO 3302-1 (class M4-F+C). The tolerances of welding seams are defined by quality group D according to EN ISO 10042, if it is not specified on the actual scale drawing or data sheet. In addition to that we point out that any data sheet and corresponding scale drawing is no substitution for the manual.

Accessories

Connector Set Rail Series



Description

The asa rail system is the first worldwide flexible mounting and connection system for air blast heat exchangers. The flexibility comes from free choice of the port's direction. Each port on the radiator has 3 possibilities. This well designed radiator concept brings another flexibility innovation hit to the standard cooler market: The oil flow direction can be chosen between u-flow direction and diagonal oil flow on each TT rail cooler!

The radiator rail slots are not only for connecting the hydraulic ports, it is also possible to have the system attached with e.g.: bypass systems, mounting of the cooler to an aggregate, measurement devices, and much more. Please contact us to discover the huge potential of this rail system for your application.

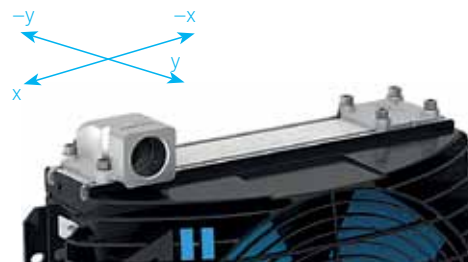

Dimensions

ported 90° connector

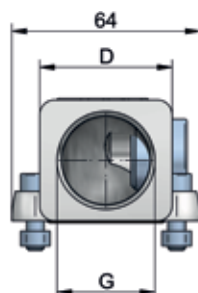
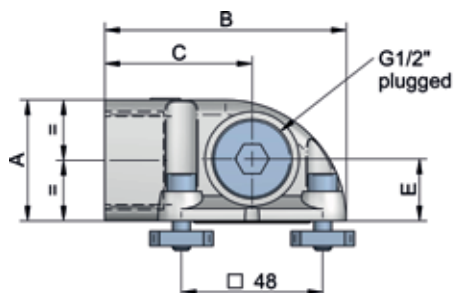

ported straight connector

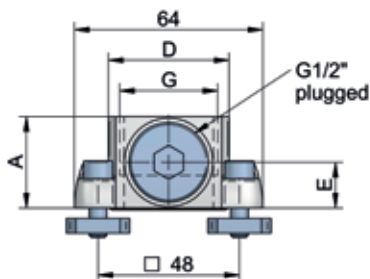

blind connector:

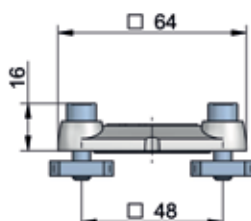

Technical Data

order number	description	o-ring	A	B	C	D	E	G	connection type	weight
			[mm]	[mm]	[mm]	[mm]	[mm]			[kg]
ILLZSET5G25	asa rail connector BSP 1"	NBR, 70 shore, 35 x 3 mm	41	82	50	45	21	BSP 1"	2x 90°	0,90
ILLZSET5G32	asa rail connector BSP 1 1/4"		50	88	56	50	21	BSP 1 1/4"	2x 90°	1,05
ILLZSET5U16	asa rail connector UN 15/16"		41	82	50	45	21	UN 15/16"	2x 90°	0,90
ILLZSET5U20	asa rail connector UN 15/8"		50	88	56	50	21	UN 15/8"	2x 90°	1,10
ILLZSET5G25A	asa rail connector BSP 1" straight		31	—	—	41	15	BSP 1"	2x straight	0,66
ILLZSET5G25B	asa rail connector BSP 1" straight+Stnd.							BSP 1"	1x 90°, 1x straight	0,77

Content

ported connector with plugged G 1/2"	2x
blind connector	1x
o-ring	3x
slot nut	12x
screw M6x20	12x

requires 1 set per cooler



packed size: 1 set

Fits On Cooler Types

TT 05 , 07 , 11 , 13 , 16 , 21 , 25

This data sheet and the corresponding scale drawings are to be used as a general guideline and technical overview of our products. Please contact us if more exact information is needed. As we are constantly improving our products, their characteristics, dimensions and weights may also change, although we do our best to incorporate these changes continually. asa assumes no liability for any information therein, any errors, omissions, misprints, nor any direct or indirect damages, losses or costs resulting therefrom. Any cooling performances and general technical values indicated in this catalogue are measured at a test bench according to asa testing procedures or calculated, based on such tests. Due to different conditions in testing and application environments the performance may also vary by +/- 15%. Because there is no standardized testing procedure, tests used by other manufacturers could have different results. Therefore we recommend all products to be checked under the system operating conditions. This is also true for vibrations and mechanical stress as well as for pressure peaks and thermal stress and any other relevant factors. General tolerances according to DIN ISO 2768-v. General tolerances for casted parts according to EN ISO 8062-3 (DCTG 10). Tolerances for rubber parts are according to ISO 3302-1 (class M4-F+C). The tolerances of welding seams are defined by quality group D according to EN ISO 10042, if it is not specified on the actual scale drawing or data sheet. In addition to that we point out that any data sheet and corresponding scale drawing is no substitution for the manual.

Accessories

Connector Set ASA Series



Description

The asa universal connector is a patented system that offers many possibilities regarding dimension and direction of the hydraulic connection.

With each connector you can choose from 3 directions how to install it into the hydraulic circuit. The stream optimized design reduces the total pressure drop on the cooler. The omission of screwed joints reduces the number of sealing surfaces. The available connector dimensions depend on the cooler size and are shown in the table below.

Our newest option is an intermediate plate for having an additional BSP 1/2" port, which can also be turned in any required direction.

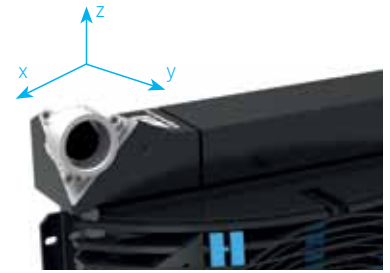

Dimensions

AUC NG 32 – 40 Connectors

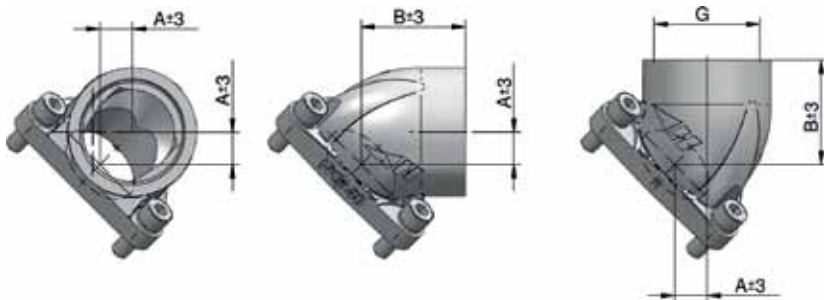

Intermediate plate NG 40

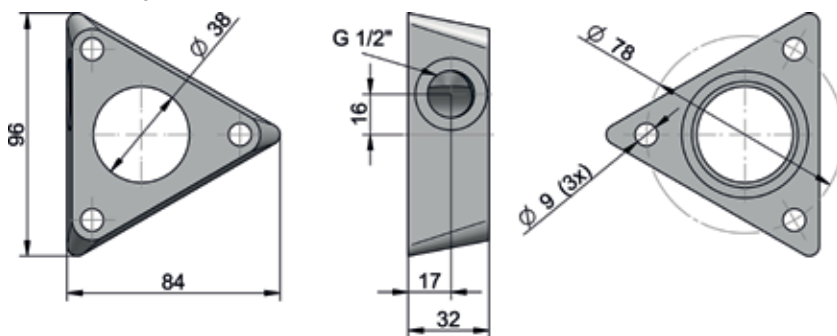

Technical Data

order number	description	A	B	G	connector material	o-ring	weight
		[mm]	[mm]				[kg]
ILLZASA32G32	AUC NG 32 – G 1 1/4"	14	34	BSP 1 1/4"	aluminum	NBR, 70 shore, 44 x 3 mm	0,31
ILLZASA40G40	AUC NG 40 – G 1 1/2"	15	47	BSP 1 1/2"			0,29
ILLZASA32U20	AUC NG 32 – UN 15/8"	14	34	UN 15/8"			0,31
ILLZASA40U24	AUC NG 40 – UN 17/8"	15	47	UN 17/8"			0,29
ILLZASA40-40G12	intermediate plate NG 40	–	–	–			0,30

Options

asa universal connector	2x
o-ring	2x
screw	6x
spring ring	6x

requires 2 pcs per cooler



packed size, 2 pieces

Fits On Cooler Types

ILLZASA32G32	ASA 0177, 0257, 0367, 0467, 0567, 0727, 0927
ILLZASA40G40	ASA 0177, 0257, 0367, 0467, 0567, 0727, 0927

This data sheet and the corresponding scale drawings are to be used as a general guideline and technical overview of our products. Please contact us if more exact information is needed. As we are constantly improving our products, their characteristics, dimensions and weights may also change, although we do our best to incorporate these changes continually. asa assumes no liability for any information therein, any errors, omissions, misprints, nor any direct or indirect damages, losses or costs resulting therefrom. Any cooling performances and general technical values indicated in this catalogue are measured at a test bench according to asa testing procedures or calculated, based on such tests. Due to different conditions in testing and application environments the performance may also vary by +/- 15%. Because there is no standardized testing procedure, tests used by other manufacturers could have different results. Therefore we recommend all products to be checked under the system operating conditions. This is also true for vibrations and mechanical stress as well as for pressure peaks and thermal stress and any other relevant factors. General tolerances according to DIN ISO 2768-v. General tolerances for casted parts according to EN ISO 8062-3 (DCTG 10). Tolerances for rubber parts are according to ISO 3302-1 (class M4-F+C). The tolerances of welding seams are defined by quality group D according to EN ISO 10042, if it is not specified on the actual scale drawing or data sheet. In addition to that we point out that any data sheet and corresponding scale drawing is no substitution for the manual.

Accessories

rubber vibration absorber, foot mounting brackets



Rubber Vibration Absorber

The asa vibration absorbers are rubber metal connected parts to absorb impact loads on components to protect them and to extend the life time of the system. The patented solution is especially designed for highest shear loads. An assembly system can be checked by arrows on the metal parts, helping to optimize and raise the load capability of the vibration absorber.

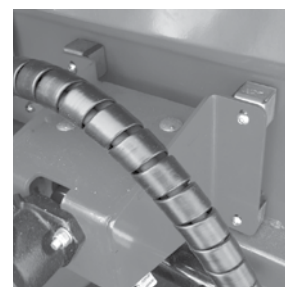
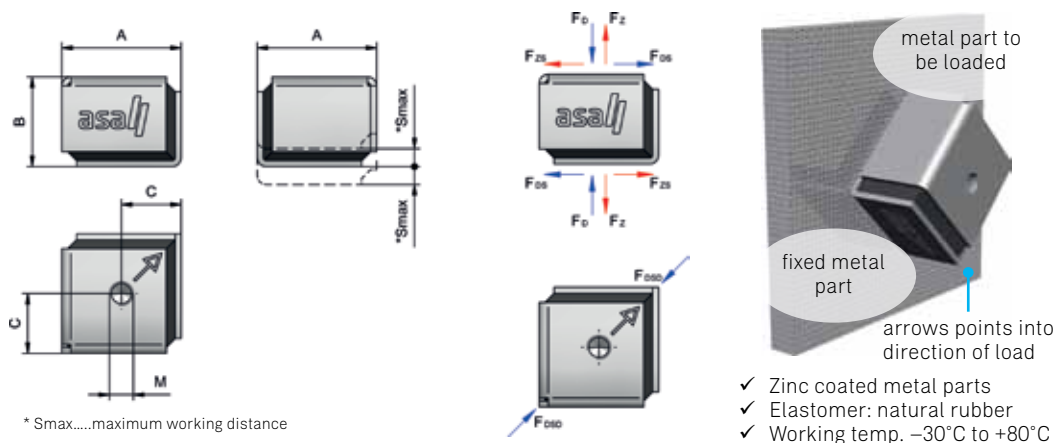

Dimensions

order number	description	A	B	C	M	Smax	weight
		[mm]	[mm]	[mm]		[mm]	[kg]
MDGQ403008II	40x40x30 M8	40	30	20	M8	± 3	0,127
MDGQ504510II	50x50x45 M10	50	45	25	M10	± 6	0,280
MDGQ755512II	75x75x55 M12	75	55	37,5	M12	± 8	0,659
MDGQ1007516II	100x100x75 M16	100	75	50	M16	± 9	1,920

Contact us for full data sheet with load capacities, maximum static loads and spring rates.

Tread Plate / Radiator Guard / Lifting Kit

The tread plates are accessories for the asa series cooler types with side frames (AC and hydraulic drive versions). The solid plates are used for applications where maintenances and servicing procedures require the cooler as a safe surface to step on. The radiator guard is a solid protection to avoid damages on the radiator air fins and oil channels. For safe and simple handling during installation and relocation only used for installation and maintenance.

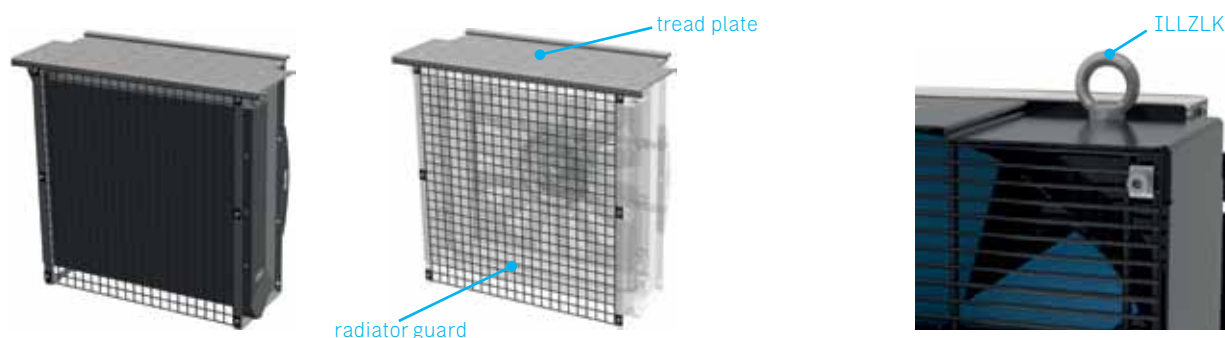

order number	description	fits on cooler type*					
		ASA 0177	ASA 0257	ASA 0367	ASA 0467	ASA 0567	ASA 0927
tread plate kit	plate, flat screws;	○	●	MW2089	○	○	○
radiator guard	grid, screws, washers;	ILLEGIT017SK	ILLEGIT025SK	ILLEGIT036SK	○	○	○

●...optional available, ○...available on request, *...DC drive versions are not compatible with these accessories

order number	description	delivery content
ILLZLK	Lifting kit standard coolers	one kit contains 2 ring bolts, 4 nylon washers and 2 screw s

This data sheet and the corresponding scale drawings are to be used as a general guideline and technical overview of our products. Please contact us if more exact information is needed. As we are constantly improving our products, their characteristics, dimensions and weights may also change, although we do our best to incorporate these changes continually. asa assumes no liability for any information therein, any errors, omissions, misprints, nor any direct or indirect damages, losses or costs resulting therefrom. Any cooling performances and general technical values indicated in this catalogue are measured at a test bench according to asa testing procedures or calculated, based on such tests. Due to different conditions in testing and application environments the performance may also vary by +/- 15%. Because there is no standardized testing procedure, tests used by other manufacturers could have different results. Therefore we recommend all products to be checked under the system operating conditions. This is also true for vibrations and mechanical stress as well as for pressure peaks and thermal stress and any other relevant factors. General tolerances according to DIN ISO 2768-v. General tolerances for casted parts according to EN ISO 8062-3 (DCTG 10). Tolerances for rubber parts are according to ISO 3302-1 (class M4-F+C). The tolerances of welding seams are defined by quality group D according to EN ISO 10042, if it is not specified on the actual scale drawing or data sheet. In addition to that we point out that any data sheet and corresponding scale drawing is no substitution for the manual.

Accessories

temperature switches



According to the cooler type and size, our temperature switches fit on all coolers and connectors with BSP ½" threads. Please contact us for the compatibility of the products. IP69K switch types (ILLZTH5069K, ILLZTH6069K and ILLZTH9069K) work in combination with our temperature control units ILLZTC12-2K (12V) and also with ILLZTC24-2K (24V). This is a simple on/off mode, according to the switch temperature. The control unit benefit is the soft start curve, extending the life time of the fan motor.

On request we offer various other bi-metal temperature switches with different temperature settings, protection classes and connection makes.

Protection IP69k



Protection IP65

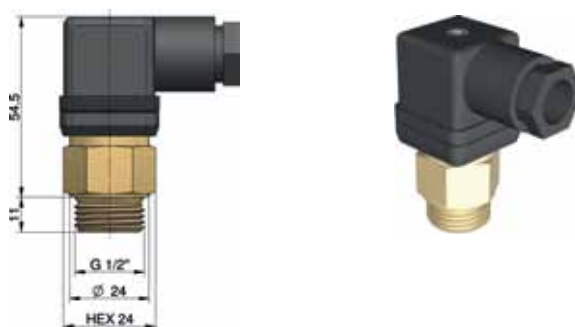

Technical Data

order number	description	connection	protection	switch temperature	differential	weight
				[°C]	[°C]	[kg]
ILLZTH5069K	temperature switch 50°C	AMP superseal 1,5	IP 69K	50 ± 5	10 ± 5	0,10
ILLZTH6069K	temperature switch 60°C	AMP superseal 1,5	IP 69K	60 ± 5	10 ± 5	0,10
ILLZTH9069K	temperature switch 90°C	AMP superseal 1,5	IP 69K	90 ± 5	10 ± 5	0,10
ILLZTH4765K	temperature switch 50°C	ISO 4400	IP 65	50 ± 5	10 ± 5	0,09
ILLZTH6065K	temperature switch 60°C	ISO 4400	IP 65	60 ± 5	10 ± 5	0,09

Characteristics

screw part material	brass
mounting	any position
max. tightening torque	40Nm
number of cycles	100.000
counter connector	included

Ambient Conditions

oil temperature range	-20°C to +100°C
ambient temperature range	-20°C to +80°C
storage temperature range	-60°C to 110°C

Combinations

all coolers and connectors with BSP ½" threads

Measurement Output

contact	N.O. (normal open)
minimum current	200mA
maximum current	12V AC: 10A
	24V AC: 10A
	120V AC: 12A
	230V AC: 10A

Use power relay for switching!

This data sheet and the corresponding scale drawings are to be used as a general guideline and technical overview of our products. Please contact us if more exact information is needed. As we are constantly improving our products, their characteristics, dimensions and weights may also change, although we do our best to incorporate these changes continually. asa assumes no liability for any information therein, any errors, omissions, misprints, nor any direct or indirect damages, losses or costs resulting therefrom. Any cooling performances and general technical values indicated in this catalogue are measured at a test bench according to asa testing procedures or calculated, based on such tests. Due to different conditions in testing and application environments the performance may also vary by +/- 15%. Because there is no standardized testing procedure, tests used by other manufacturers could have different results. Therefore we recommend all products to be checked under the system operating conditions. This is also true for vibrations and mechanical stress as well as for pressure peaks and thermal stress and any other relevant factors. General tolerances according to DIN ISO 2768-v. General tolerances for casted parts according to EN ISO 8062-3 (DCTG 10). Tolerances for rubber parts are according to ISO 3302-1 (class M4-F+C). The tolerances of welding seams are defined by quality group D according to EN ISO 10042, if it is not specified on the actual scale drawing or data sheet. In addition to that we point out that any data sheet and corresponding scale drawing is no substitution for the manual.



Thermal Systems Connection Technology Fluid Controls



AUSTRIA

asa hydraulik GmbH
Prager Strasse 280
A-1210, Vienna
Tel.: +43 1 292 40 20
support@asahydraulik.com

USA

asa hydraulik of America
160 Meister Avenue 20 A
Branchburg, New Jersey 08876
Tel.: +1 800 473 94 00
Tel.: +1 908 541 15 00
sales_us@asahydraulik.com

CHINA

安飒液压科技（苏州）有限公司
asa Hydraulik Technology (Suzhou) Co.Ltd
江苏省苏州市工业园区方洲路128号6区B幢
Area 6, Building B,
Fangzhou Road No 128,
Suzhou industrial park,
Suzhou City, Jiangsu Province
Tel.: +86 512 62381988
suzhou@asahydraulik.com

AUSTRALIA

asa Products Pty Ltd
Bentley Street 4/15
3016 Williamstown, Victoria
Tel.: +61 3 9397 6129
melbourne@asahydraulik.com

INDIA

ASAhdraulik India Pvt Ltd
C1/109/9, GIDC, Palej, Dt.Bharuch
Gujarat – 392220
Tel.: +91 22 28195557
salesindia@asahydraulik.com